

# REGULATOR RG90M3/4XLN7/8

## PO.70MBAR 6M3/H UPSO

### CODE 100179

With an inlet pressure between 100 and 500mbar, the regulator maintains the outlet pressure between 65 and 75mbar for flow rates between 0.6 and 6m<sup>3</sup>/h.



## FEATURES

- Inlet pressure: 100-500mbar
- Output pressure: 65-75mbar
- Securities: UPSO (15mbar)
- Nominal flow rate: 6m<sup>3</sup>/h
- Pressure tapping: -
- Connections: M3/4xLN7/8
- Disposition: 90°
- Conduction for venting: -

## DIMENSIONS

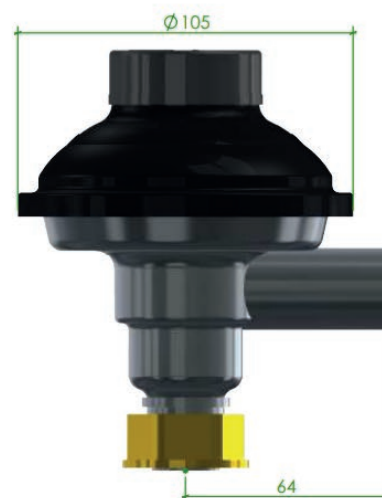
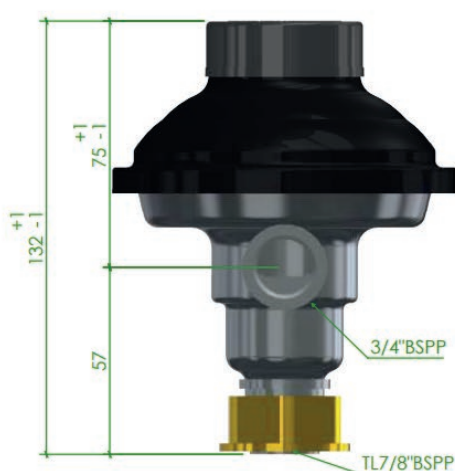

## MATERIALS

- Membranes and seals, in NBR resistant to Liquefied Petroleum Gas (LPG), Natural Gas (NG) and Synthetic Natural Gas (SNG)
- Aluminum body
- Galvanized steel cover
- Cataphoresis treatment with high resistance on cover and body
- Galvanized steel springs
- Non-metallic internal parts, in PA with fiberglass and acetal resin (POM)
- Stainless steel filter
- Manufactured in the EU

## COMPLIANCE WITH STANDARDS



AENOR certificate in accordance with the UNE 60402-1 (2008) standard



CE-certified according to EN 88-1:2011 + A1:2016, EN 13611:2019 and EN13611:2019/AC:2021

## INSTALLATION AND COMMISSIONING

- ✓ Check inlet pressure. It must not exceed 500 mbar.
- ✓ Fit the regulator respecting the gas flow. See flow arrow on the bottom of the regulator.
- ✓ Once the regulator is in place, check that there are no leaks at the regulator connections.
- ✓ With all consumption points downstream of the regulator closed, open the gas tap upstream of the regulator.
- ✓ In the case of automatic VIS MIN, wait a few seconds (approx. 15-20) until the VIS is reset.
- ✓ In case of manual VIS MIN, actuate the reset device on the controller (by pulling on it) for about 2 seconds.
- ✓ The regulator will start to regulate when there is any demand for consumption.

## BEHAVIOURAL CURVES

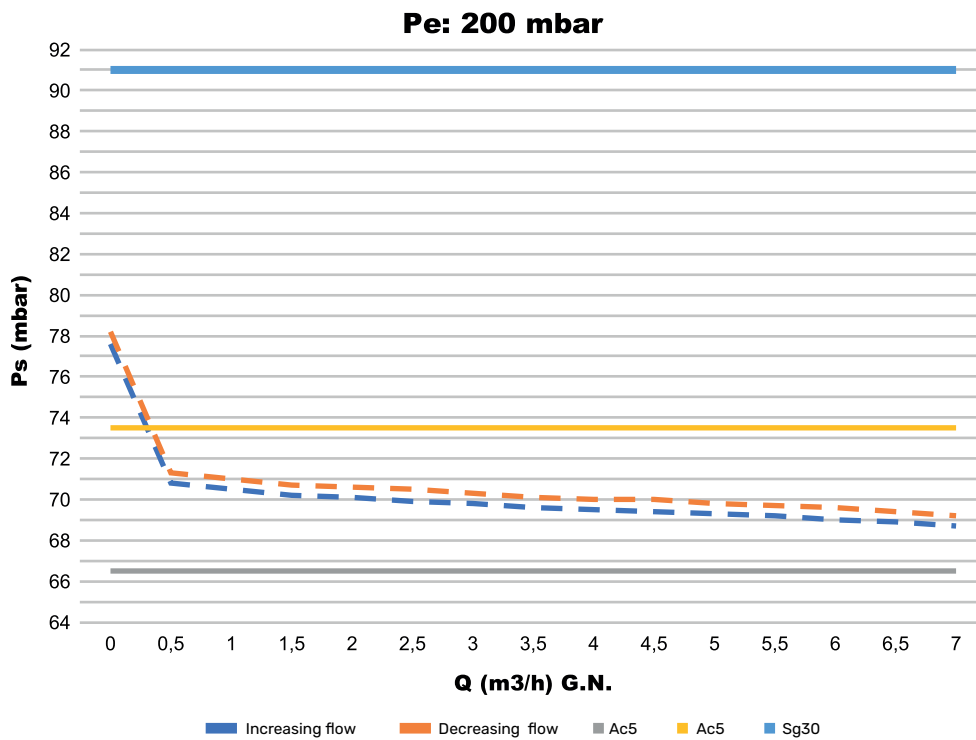
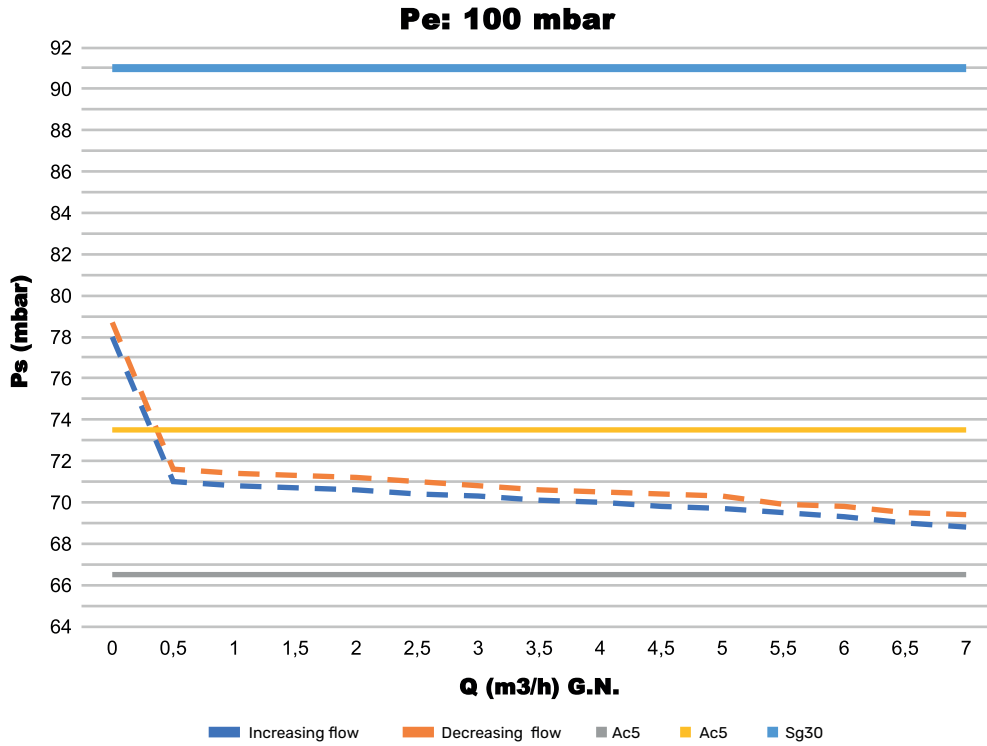

## BEHAVIOURAL CURVES

