

REGULATOR RG180MM20/150 PO.21MBAR 6M3/H UPSO W/PRESSURE GAUGE SOCKET CODE 200161

With an inlet pressure between 25 and 500mbar, the regulator maintains the outlet pressure between 19 and 23mbar for flow rates between 0.6 and 6m³/h.

FEATURES

- Inlet pressure: 25-500mbar
- Output pressure: 19-23mbar
- Securities: UPSO (15mbar)
- Nominal flow rate: 6m³/h
- Pressure tapping: Output (1/8)
- Connections: MM20/150
- Disposition: 180°
- Conduction for venting: -



DIMENSIONS

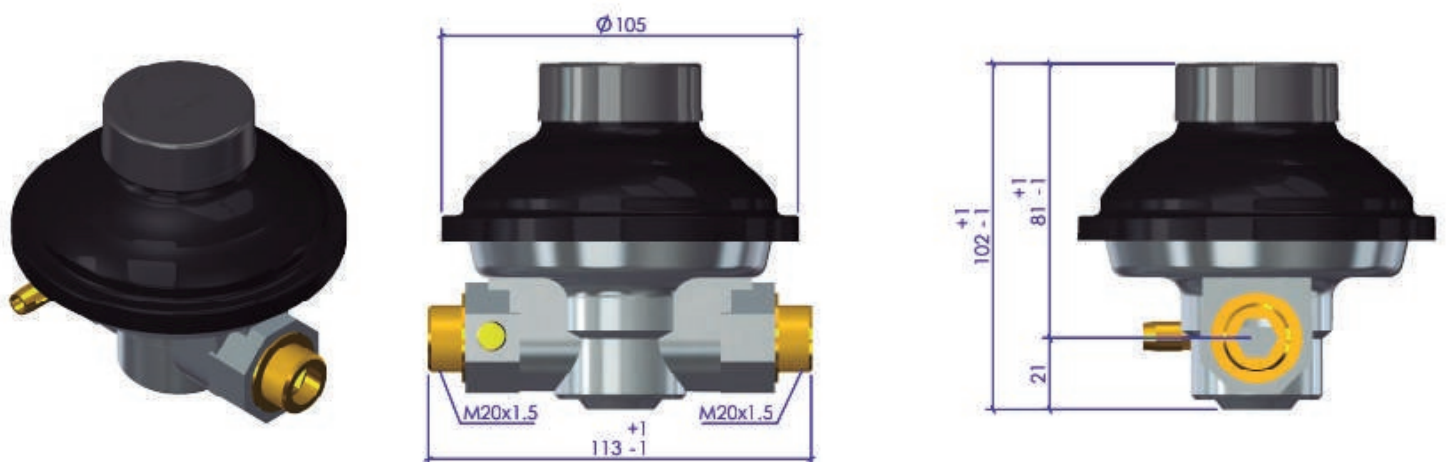

MATERIALS

- Membranes and seals, in NBR resistant to Liquefied Petroleum Gas (LPG), Natural Gas (NG) and Synthetic Natural Gas (SNG)
- Aluminum body
- Galvanized steel cover
- Cataphoresis treatment with high resistance on cover and body
- Galvanized steel springs
- Non-metallic internal parts, in PA with fiberglass and acetal resin (POM)
- Stainless steel filter
- Manufactured in the EU

COMPLIANCE WITH STANDARDS



AENOR certificate in accordance with the UNE 60402-1 (2008) standard



CE-certified according to EN 88-1:2011 + A1:2016, EN 13611:2019 and EN13611:2019/AC:2021

INSTALLATION AND COMMISSIONING

- ✓ Check inlet pressure. It must not exceed 500 mbar.
- ✓ Fit the regulator respecting the gas flow. See flow arrow on the bottom of the regulator.
- ✓ Once the regulator is in place, check that there are no leaks at the regulator connections.
- ✓ With all consumption points downstream of the regulator closed, open the gas tap upstream of the regulator.
- ✓ In the case of automatic VIS MIN, wait a few seconds (approx. 15-20) until the VIS is reset.
- ✓ In case of manual VIS MIN, actuate the reset device on the controller (by pulling on it) for about 2 seconds.
- ✓ The regulator will start to regulate when there is any demand for consumption.

BEHAVIOURAL CURVES

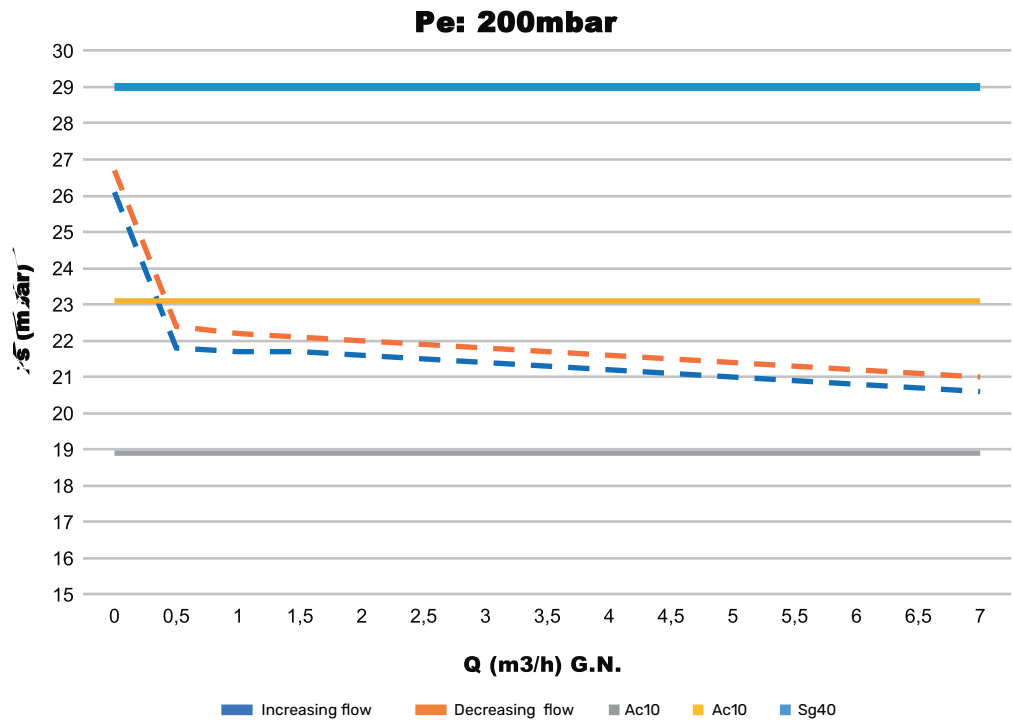
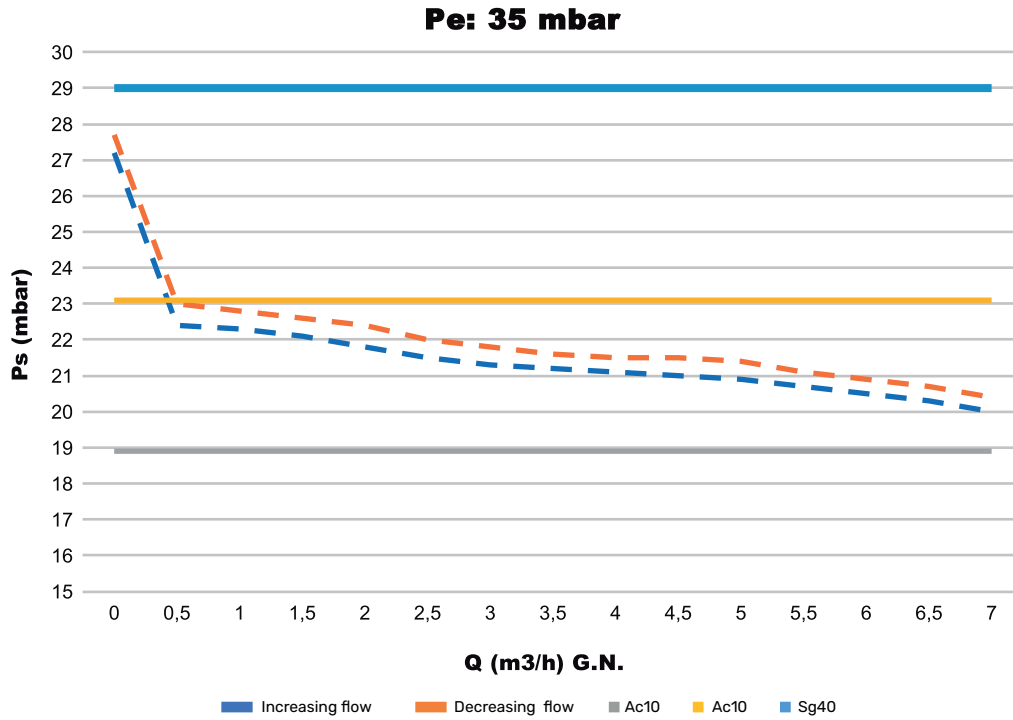

BEHAVIOURAL CURVES

