

# REGULATOR

## RG180 FF3/4 PO.37MBAR

### 7,2KG/H UPSO (MANUAL)

#### CODE 200043

With an inlet pressure between 50 and 500mbar, the regulator maintains the outlet pressure between 34 and 40mbar for flow rates between 0.5 and 7.2Kg/h.



## FEATURES

- Inlet pressure: 50-500mbar
- Output pressure: 34-40mbar
- Securities: UPSO (27mbar) manual reset
- Nominal flow rate: 7.2kg/h
- Pressure tapping: -
- Connections: FF3/4
- Disposition: 180°
- Conduction for venting: -

## DIMENSIONS

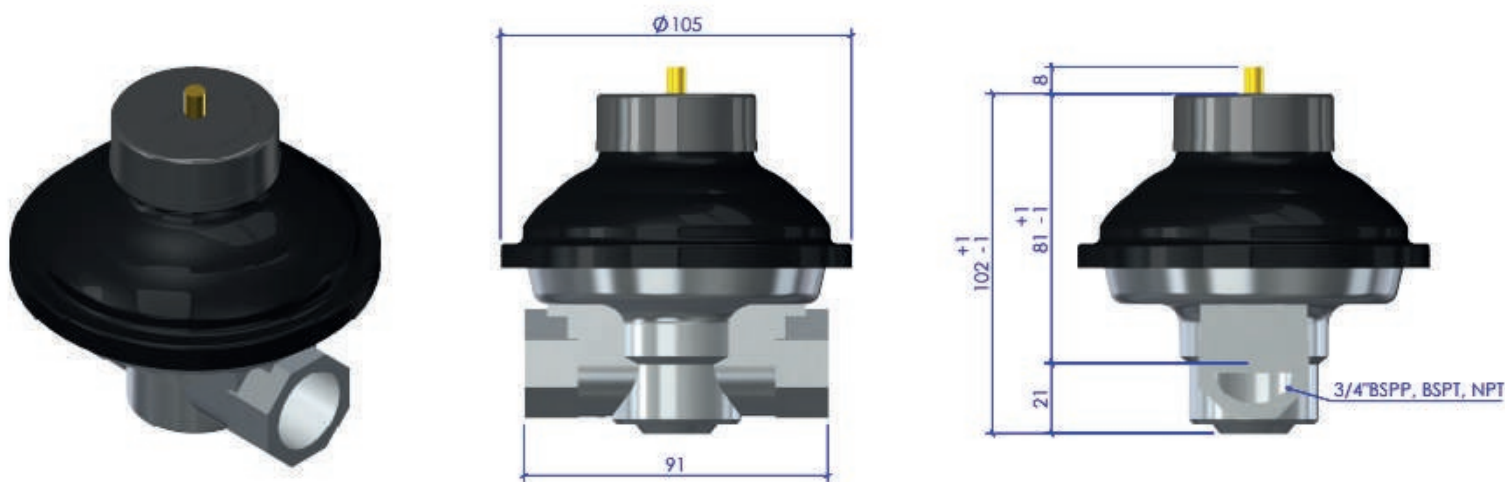

## MATERIALS

- Membranes and seals, in NBR resistant to Liquefied Petroleum Gas (LPG), Natural Gas (NG) and Synthetic Natural Gas (SNG)
- Aluminum body
- Galvanized steel cover
- Cataphoresis treatment with high resistance on cover and body
- Galvanized steel springs
- Non-metallic internal parts, in PA with fiberglass and acetal resin (POM)
- Stainless steel filter
- Manufactured in the EU

## COMPLIANCE WITH STANDARDS



AENOR certificate in accordance with the UNE 60402-1 (2008) standard



CE-certified according to 88-1:2011 + A1:2016, EN 13611:2019 and EN13611:2019/AC:2021

## INSTALLATION AND COMMISSIONING

- ✓ Check the inlet pressure. It must not exceed 500 mbar.
- ✓ Fit the regulator respecting the gas flow. See flow arrow on the bottom of the regulator.
- ✓ Once the regulator is in place, check that there are no leaks at the regulator connections.
- ✓ With all consumption points downstream of the regulator closed, open the gas tap upstream of the regulator.
- ✓ If the controller is equipped with automatic VIS MIN, wait a few seconds (approx. 15-20) until the VIS is reset.
- ✓ In the case of manual VIS MIN, actuate the reset device on the controller (by pulling on it) for about 2 seconds.
- ✓ The controller will start to regulate when any consumption demand occurs.

# BEHAVIOURAL CURVES

**Pe: 50mbar**

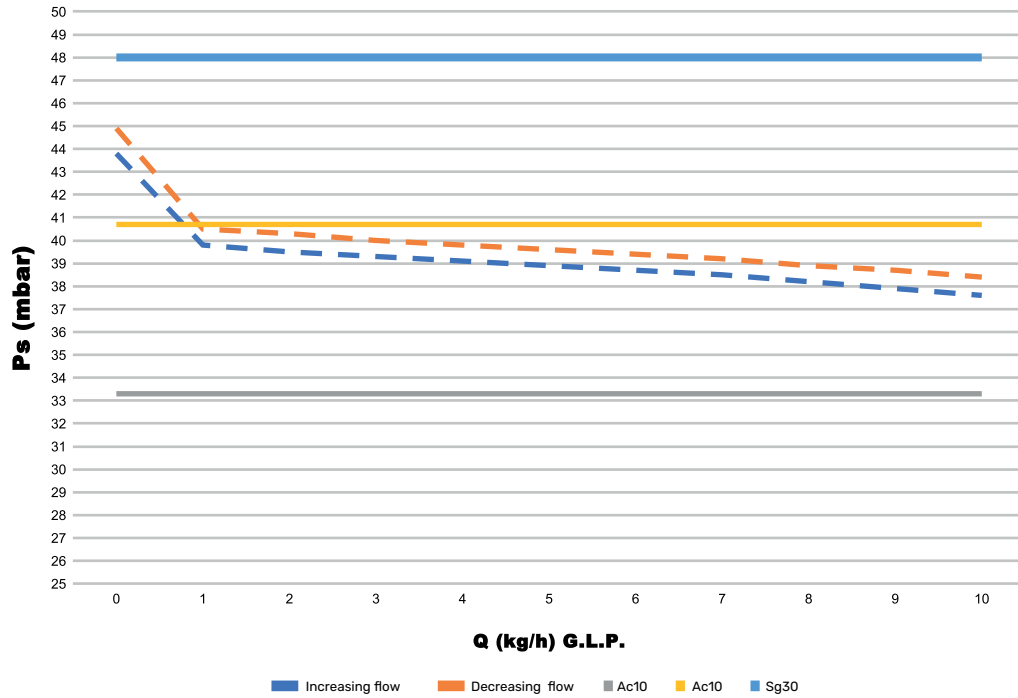

**Pe: 200mbar**

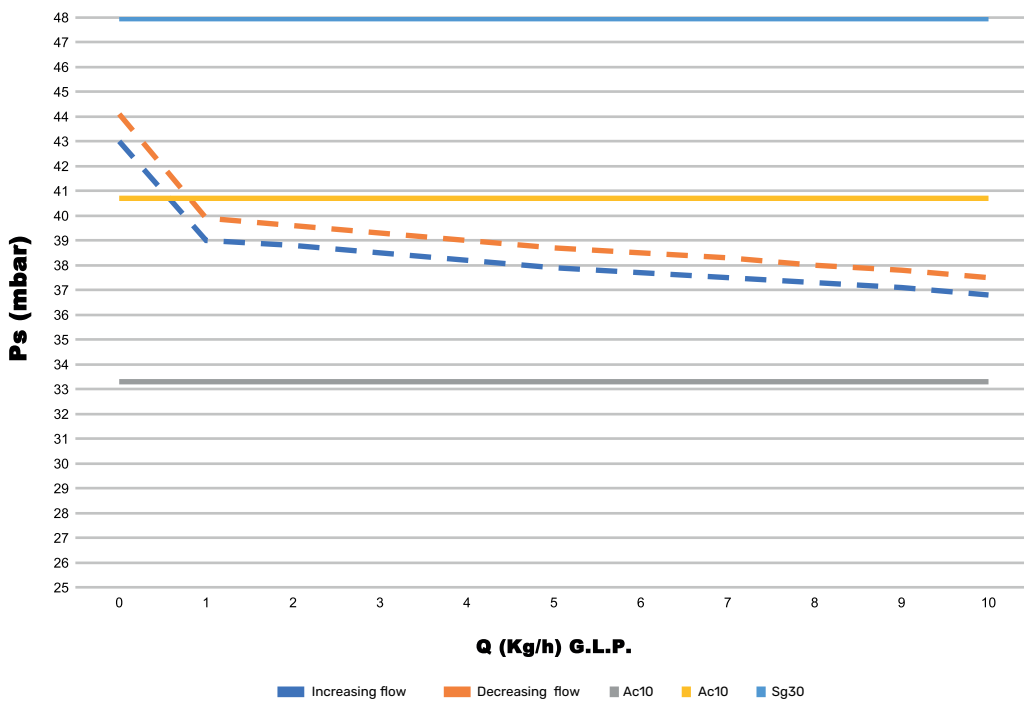

# BEHAVIOURAL CURVES

