

# REGULATOR RG180 LN3/4XF3/4 PO.150MBAR 10KG/H UPSO (MANUAL), OPSO (MANUAL) CODE 700009

With an inlet pressure between 1 and 6bar, the regulator maintains the outlet pressure between 140 and 160mbar for flow rates between 1 and 10kg/h.

## FEATURES

- Inlet pressure: 1-6bar
- Output pressure: 140-160mbar
- Securities: UPSO (100mbar) manual reset, OPSO (300mbar) manual reset
- Nominal flow rate: 10kg/h
- Pressure tapping: -
- Connections: LN3/4x3/4
- Disposition: 180°
- Conduction for venting: -



## DIMENSIONS

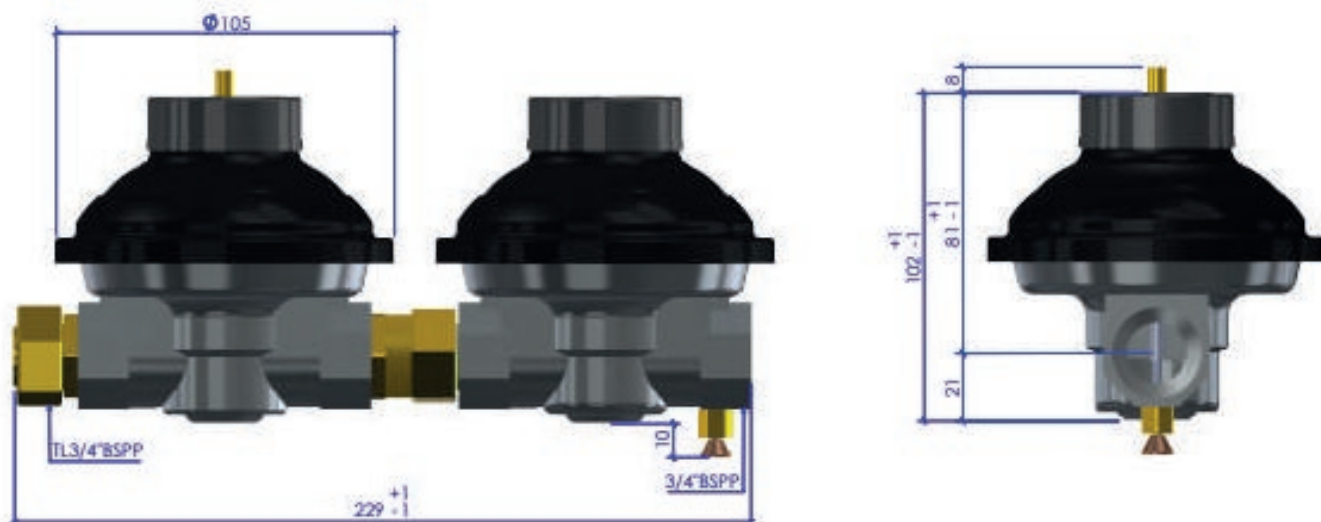

## MATERIALS

- Membranes and seals, in NBR resistant to Liquefied Petroleum Gas (LPG), Natural Gas (NG) and Synthetic Natural Gas (SNG)
- Aluminum body
- Galvanized steel cover
- Cataphoresis treatment with high resistance on cover and body
- Galvanized steel springs
- Non-metallic internal parts, in PA with fiberglass and acetal resin (POM)
- Stainless steel filter
- Manufactured in the EU

## COMPLIANCE WITH STANDARDS



AENOR certificate in accordance with the UNE 60402-1 (2008) standard



CE-certified according to 88-1:2011 + A1:2016, EN 13611:2019 and EN13611:2019/AC:2021

## INSTALLATION AND COMMISSIONING

- ✓ Check the inlet pressure. It must not exceed 6 bar.
- ✓ Fit the regulator respecting the gas flow. See flow arrow on the bottom of the regulator.
- ✓ Once the regulator is in place, check that there are no leaks at the regulator connections.
- ✓ With all consumption points downstream of the regulator closed, open the gas tap upstream of the regulator.
- ✓ If the regulator is fitted with automatic VIS MIN, wait a few seconds (approx. 15-20) until the VIS is reset.
- ✓ In the case of manual VIS MIN, operate the reset device on the controller (by pulling on it) for about 2 seconds.
- ✓ Once VIS MIN has been reset, act on the VIS MAX reset device (located on the second body) for about 2 seconds.
- ✓ The regulator will start to regulate when any consumption demand occurs.

# BEHAVIOURAL CURVES

**Pe: 1bar**

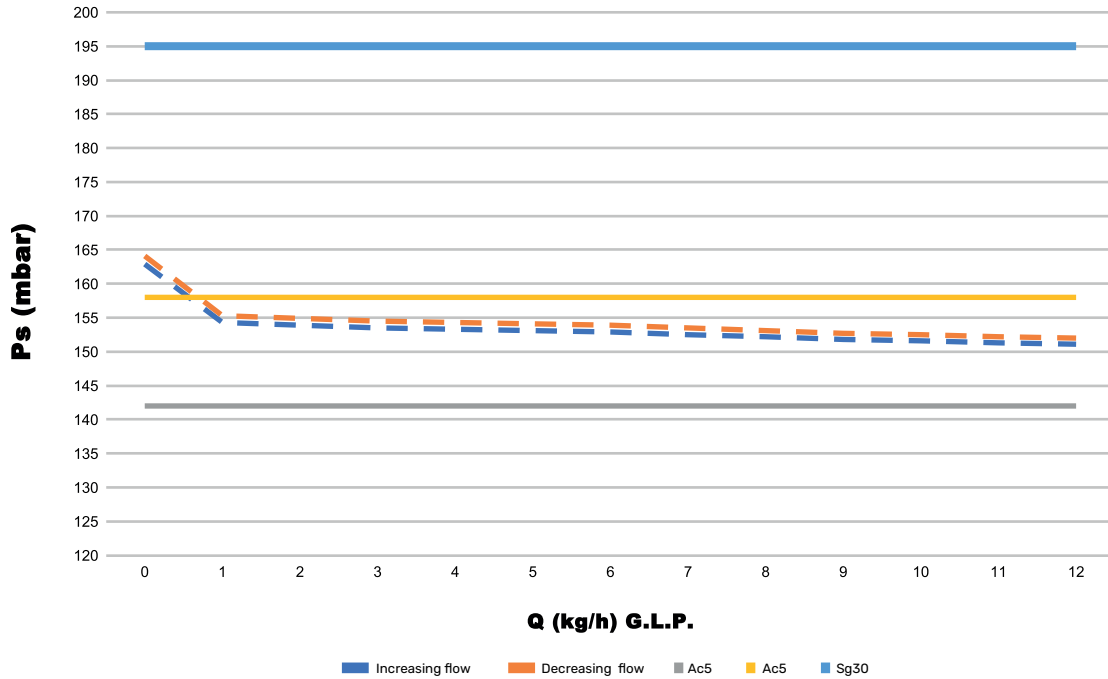

**Pe: 2,5bar**

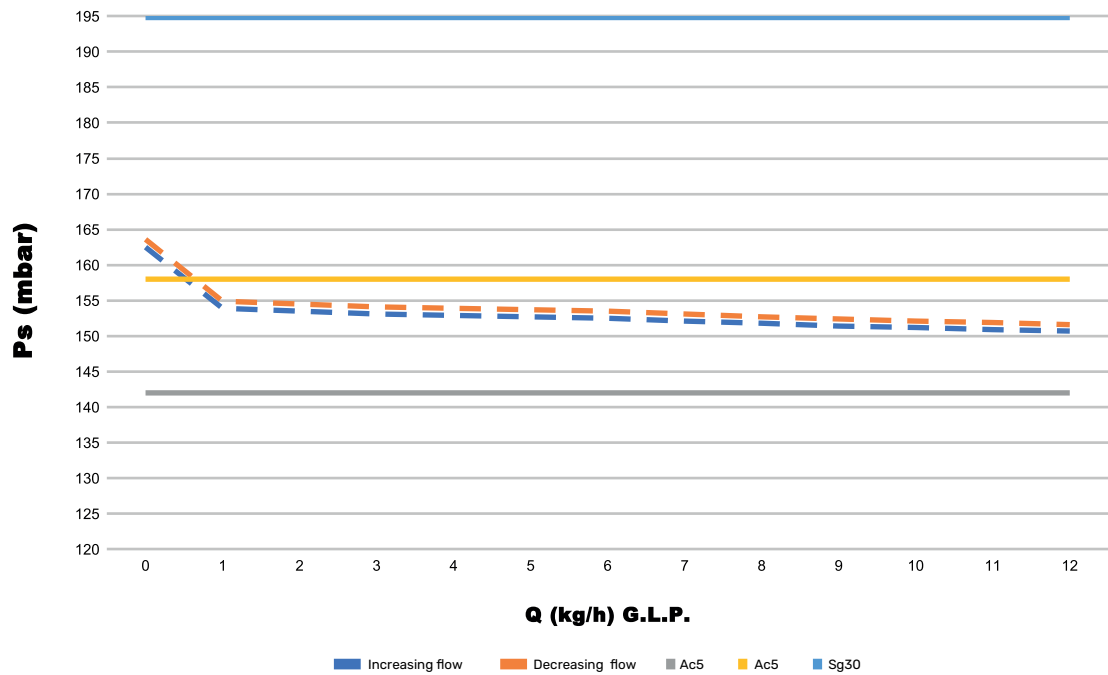

# BEHAVIOURAL CURVES

**Pe: 5bar**

